



since 1983



**INNER TUBES
AND FLAPS
MADE IN EUROPE**

ISO 9001

BUREAU VERITAS
Certification



ISO 14001

BUREAU VERITAS
Certification



PN-N 18001

BUREAU VERITAS
Certification



www.kabat.pl

OUR EXPORT

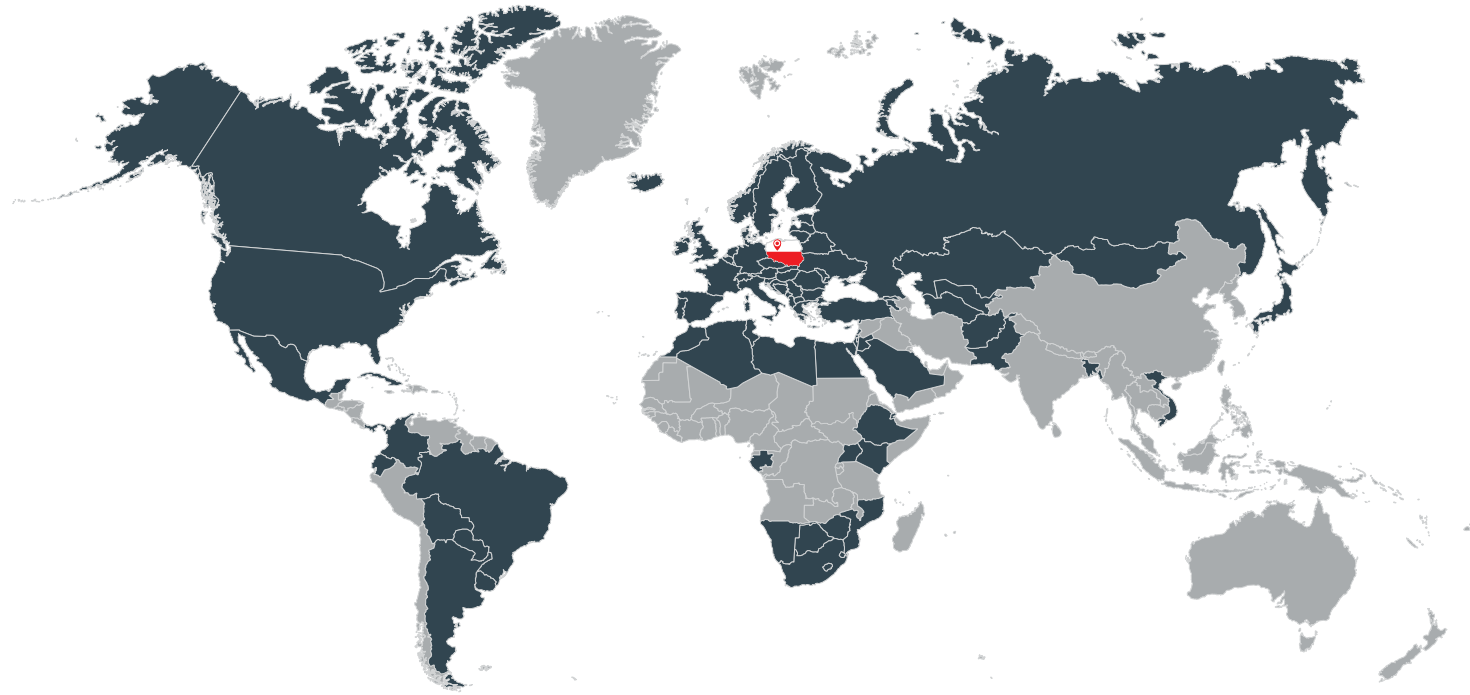

Kabat Company was established in 1983 by two brothers - Andrzej and Tadeusz Kabat. Since then they have been co-owners of the company and today the company is still a family business.

At the beginning the company was a craftsmen shop, providing services for tyre and inner tube repairing, and tyre retreading - all this was done in a space of merely 21 m². Today the whole facility area takes 70.000 m² and the company employs 900 people. A new facility is the factory in Bolechowo, close to Poznań.

Our core business are tyre inner tubes; besides them we also produce agricultural tyres, solid tyres, flaps, rubber compounds, rubber profiles (e.g. for fenestration joinery PVC and ALU), rubber mats and car rugs. Our offer grows continuously and we strive to provide our clients with a wide range of products.

In October 2011 we produced the first pneumatic Kabat branded tyre. It's the result of our investment, which was finalized with the erection of a new hall for the production of agricultural and implement tyres. In May 2014 the first solid superelastic Kabat brand tyre has been produced. The annual production of the company reached the level of 20.000 tons of rubber products.

Our strengths are flexibility, high quality products and service. Our technical background consists of four mixer lines with mills, calendars, extruders and hydraulic presses. We also own a design studio and a complete R&D department, which allows us to quickly respond to clients' and market requirements and to implement new products.

We are a leading inner tube producer in Europe and we are also in the forefront of the world's largest inner tube manufacturers. Our products find their way to customers in 80 countries on 5 continents.

Since 2006 we have been working in conformity to quality management systems **ISO 9001:2008** (production), **ISO 14001:2004** (environmental protection) and **PN-N 18001:2004** (health and safety at work), certified by Bureau Veritas. In 2003 our company has been certified with **NCAGE** (NATO Commercial and Government Entity Code), which helps us to take part in tenders for armies of many countries.

ISO 9001

BUREAU VERITAS
Certification



ISO 14001

BUREAU VERITAS
Certification



PN-N 18001

BUREAU VERITAS
Certification



INNER TUBES



TUBES FOR TRUCKS

		CODE	SIZE	ADDITIONAL DESCRIPTION	VALVE	Q-TY PER BOX
15"	1	DET077	7.00-15	7.00R15	V3.04.10	20
	2	DET095	7.00-15	7.00R15	TR-75A	20
	3	DET081	7.50-15	7.50R15	V3.02.18	18
	4	DET074	7.50/8.15-15	7.50/8.15R15	TR-75A	20
	5	DET073	8.15-15	8.15R15	TR-177A	20
	6	DEC004	8.25-15	8.25R15	V 3.02.8	15
	7	DEC133	8.25-15	8.25R15	V3.04.5	15
	8	DEC030	8.25-15	8.25R15	TR-75A	15
	9	DEC001	8.40-15	8.40R15	TR-15	15
	10	DEC314	10.00-15	10.00R15	V3.02.8	12
	11	DEC421	10.00-15	10.00R15	TR78A	12
	12	DEC051	12.5/60-15	12.5/60R15	V3.02.5	12
16"	13	DEC003	7.50-16	7.50R16	V3.02.18	18
	14	DEC102	7.50-16	7.50R16	V3.02.8	18
	15	DER264	7.50-16	7.50R16	TR-75A	18
	16	DEC412	7.50-16	7.50R16	TR78A	18
	17	DEC363	7.50-16	7.50R16	TR177A	18
	18	DEC229	8.25-16	8.25R16	V3.04.5	12
	19	DEC310	8.25-16	8.25R16	TR75A	12
	20	DEC359	8.25-16	8.25R16	TR78A	12
	21	DEC422	8.25-16	8.25R16	TR177A	12
	22	DEC006	9.00-16	9.00R16	V3.02.8	12
	23	DER164	9.00-16	9.00R16	TR-177A	12
	24	DER356	9.00-16	9.00R16	TR-75A	12
	25	DEC155	10.5-16	10.5R16	V3.02.8	12
	26	DEC473	10.5-16	10.5R16	TR177A	12
	27	DEC423	11.00-16	11.00R16	TR177A	10
	28	DEC085	11.00/12.00-16	11.00/12.00R16	V3.04.10	10
	29	DEC086	13.00-16	13.00R16	V3.04.10	10
16.5"	30	DEC154	10.5-16.5	10.5R16.5	V3.06.8	12
17.5"	31	DEC336	8.5R17.5	8.5R17.5	V53.21.1	15
	32	DEC173	215/75-17.5	215/75R17.5	V3.02.18	15
18"	33	DEC014	12.00-18	12.00R18	V3.02.8	7
	34	DEC393	12.00-18	12.00R18	PK-5A	7
	35	DEC015	13.00-18	13.00R18	V3.02.8	6
	36	DEC244	13.00-18 HD (military)	13.00R18 HD (military)	PK-5A	5
	37	DEC592	15.5/65-18	15.5/65R18	TR-175A	6
20"	38	DEC149	6.50/7.00-20	6.50/7.00R20	V3.04.5	15
	39	DEC002	6.50/7.00-20	6.50/7.00R20	V3.02.18	15
	40	DET121	6.50/7.00-20	6.50/7.00R20	TR-75A	15
	41	DEC323	6.50/7.00-20	6.50/7.00R20	TR177A	15
	42	DEC191	7.50-20	7.50R20	V3.02.8	15
	43	DEC193	7.50-20	7.50R20	V3.04.5	15
	44	DET122	7.50-20	7.50R20	TR-75A	15
	45	DEC226	7.50-20	7.50R20	TR177A	15
	46	DEC018	7.50-20	7.50R20	V3.06.3	15
	47	DEC005	8.25-20	8.25R20	V3.02.10	12
	48	DEC475	8.25-20	8.25R20	TR78A	12
	49	DEC355	8.25-20	8.25R20	TR177A	12
	50	DEC007	9.00-20	9.00R20	V3.02.11	10
	51	DEC055	9.00-20	9.00R20	V3.06.8	10
	52	DEC082	9.00-20	9.00R20	V3.04.5	10
	53	DEC447	9.00-20	9.00R20	TR75A	10
	54	DEC416	9.00-20	9.00R20	TR78A	10
	55	DEC476	9.00-20	9.00R20	TR175A	10
	56	DEC267	9.00-20	9.00R20	TR177A	10
	57	DEC008	10.00-20	10.00R20	V3.02.14	10
	58	DEC045	10.00-20	10.00R20	V3.06.8	10

		CODE	SIZE	ADDITIONAL DESCRIPTION	VALVE	Q-TY PER BOX	
20"	59	DEC083	10.00-20	10.00R20	V3.04.5	10	
	60	DEC182	10.00-20	10.00R20	V3.02.5	10	
	61	DEC206	10.00-20	10.00R20	TR-87	10	
	62	DEC376	10.00-20	10.00R20	TR78A	10	
	63	DEC356	10.00-20	10.00R20	TR177A	10	
	64	DEC009	11.00-20	11.00R20	V3.02.14	8	
	65	DEC084	11.00-20	11.00R20	V3.04.5	8	
	66	DEC048	11.00-20	11.00R20	V3.06.18	8	
	67	DEC417	11.00-20	11.00R20	TR78A	8	
	68	DEC357	11.00-20	11.00R20	TR177A	8	
	69	DEC424	11.00-20	11.00R20	TR179A	8	
	70	DEC050	12.00-20	12.00R20	V3.02.14	6	
	71	DEC052	12.00-20	12.00R20	V3.06.8	6	
	72	DEC174	12.00-20	12.00R20	V3.06.17	6	
	73	DEC270	12.00-20	12.00R20	TR-78A	8	
	74	DEC358	12.00-20	12.00R20	TR177A	6	
	75	DEC320	12.00-20	12.00R20	TR179A	6	
	76	DEC390	1200/500-508	1200/500R508	PK-5A	6	
	77	DEC017	14.00-20	14.00R20	V3.06.8	6	
	78	DEC057	14.00-20	14.00R20	V3.02.14	6	
	79	DEC101	14.00-20	14.00R20	V3.04.5	6	
	80	DEC360	14.00-20	14.00R20	TR177A	6	
	81	DEC249	14.00-20	14.00R20	TR-179A	6	
	82	DEC271	14.00-20	14.00R20	TR-78A	6	
	83	DEC250	14.5R20	14.5R20	V3.02.16	6	
	84	DEC031	16.00-20	16.00R20	V3.06.8	5	
	85	DEC425	16.00-20	16.00R20	TR179A	5	
	86	DEC295	18.0/70-20	18.0/70R20	V3.04.5	5	
	87	DER354	20.0/70-20	20.0/70R20	V3.06.8	5	
	21"	88	DEC260	15.00-21 (military)	15.00R21 (military)	V590	2
		89	DEC232	15.00-21 (military)	15.00R21 (military)	TRJ-1175C	2
		90	DEC387	1200/400-533	1200/400R533	PK-5A	3
		91	DEC480	1220/400-533	1220/400R533	V3.02.14	5
		92	DEC595	425/85-21	425/85R21	V3.06.8	5
	93	DEC389	1300/530-533	1300/530R533	PK-5A	2	
	22"	94	DEC188	11.00-22	11.00R22	V3.06.5	7
	22.5"	95	DEC033	9.00-R22.5	9.00RR22.5	V3.06.3	12
96		DEC034	10.00-R22.5	10.00RR22.5	V3.06.2	10	
97		DEC035	11.00-R22.5	11.00RR22.5	V3.06.3	8	
98		DEC036	12.00-R22.5	12.00RR22.5	V3.06.2	8	
99		DEC037	13.00-R22.5	13.00RR22.5	V3.06.2	6	
100		DEC038	15.00-R22.5	15.00RR22.5	V3.06.2	5	
101		DER392	315/80R22.5	315/80R22.5	VS3.21.1	6	
102		DER395	385/65R22.5	385/65R22.5	VS3.21.1	5	
24"		103	DEC124	12.00-24	12.00R24	V3.06.8	6
		104	DEC097	12.00-24	12.00R24	V3.02.15	6
	105	DEC265	12.00-24	12.00R24	TR78A	6	
	106	DEC325	12.00-24	12.00R24	TR179A	6	
	107	DEC021	13.00-24	13.00R24	V3.02.14	6	
	108	DEC428	13.00-24	13.00R24	TR78A	6	
	109	DEC075	13.00-24	13.00R24	TR177A	6	
	110	DEC013	14.00-24	14.00R24	V3.04.5	6	
	111	DEC099	14.00-24	14.00R24	V3.04.22	6	
	112	DEC109	14.00-24	14.00R24	V3.02.14	6	
	113	DEC058	14.00-24	14.00R24	TR177A	6	
	114	DEC426	14.00-24	14.00R24	TR179A	6	
	115	DER137	16.00-24	16.00R24	V3.04.22	4	
	116	DEC177	16.00-24 HD	16.00R24 HD	V3.02.17	3	
	117	DEC169	18.00-25	18.00R25	V3.02.17	3	
	118	DEC494	21.00-28	21.00R28	V3.02.17	3	
	25"	119	DEC169	18.00-25	18.00R25	V3.02.17	3
	28"	120	DEC494	21.00-28	21.00R28	V3.02.17	3

TUBES FOR CARS

		CODE	SIZE	ADDITIONAL DESCRIPTION	VALVE	Q-TY PER BOX
10"	1	DET044	145-10	ER10 145R10	TR-13	50
	2	DEO001	125/135-12	DR12 YK-12 125/135R12	TR-13	50
12"	3	DEO066	125/135-12	DR12 125/135R12	TR-15	50
	4	DEO002	145/155-12	ER12 YK-12 145/155R12	TR-13	35
	5	DEO070	155/165/175/70-12	FR12 155/165/175/70R12	TR-13	35
13"	6	DEO003	135/70-13; 145/70-13	ER13 135/70R13; 145/70R13	TR-13	40
	7	DEO004	145/70;155/70-13	145/70;155/70R13	TR-13	35
	8	DEO012	165/70-13	FR13 YK-13 165/70R13	TR-13	35
	9	DEO005	175/70-13	YKR13-02 175/70R13	TR-13	30
	10	DEO024	6.00/6.50-13	6.00/6.50R13	TR-13	30
	11	DEO076	185/195/205-13	GR13 185/195/205R13	TR-13	20
	12	DEO073	215/225/235-13	KR13 215/225/235R13	TR-13	20
	13	DEO072	7.50-13	7.50R13	TR-13	20
14"	14	DEO032	4.00/4.50-14	ER14 4.00/4.50R14	TR-15	35
	15	DEO006	165/175/70-14	FR14 YKR14 165/175/70R14	TR-13	30
	16	DEO007	175/185-14	GR14 175/185R14	TR-13	25
	17	DEO055	195/205-14	KR14 YKR14-02 195/205R14	TR-13	20
15"	18	DEO071	125-15	DR15 125R15	TR-13	40
	19	DER312	4.00/4.50-15	4.00/4.50R15	TR-15	40
	20	DEO074	135/140/145/150-15 155/70-15	ER15 135/140/145/150R15 155/70R15	TR-13	35
	21	DEO029	5.00-15	5.00R15	TR-13	35
	22	DEO023	165/175/70-15	FR15 165/175/70R15	TR-13	25
	23	DEO010	175/185/70-15	GR15 175/185/70R15	TR-13	25
	24	DEO009	175/185/70-15	GR15 175/185/70R15	TR-15	25
	25	DEO028	195/205-15	KR15 195/205R15	TR-13	20
	26	DEO069	215/225/235/70-15	MR15 215/225/235/70R15	TR-13	20
	16"	27	DEO038	5.00/5.50-16	5.00/5.50R16	TR-15
28		DEO044	5.00/5.50-16	5.00/5.50R16	TR-13	25

4 x 4 TUBES

		CODE	SIZE	ADDITIONAL DESCRIPTION	VALVE	Q-TY PER BOX
15"	1	DTE001	235/75 R15		TR-13	20
	2	DTE002	225/70 R15		TR-13	20
	3	DTE003	255/70 R15		TR-13	15
	4	DTE004	265/70 R15		TR-13	15
	5	DTE005	30X9.50 R15		TR-13	15
	6	DTE006	31x10.50 R15		TR-13	15
	7	DTE015	32x11.50 R15		TR-13	12
	8	DTE018	33x12.50 R15		TR-13	10
	9	DTE019	35x12.50 R15		TR-13	10
16"	10	DTE007	235/85 R16		TR-13	18
	11	DTE008	225/75 R16		TR-13	18
	12	DTE009	245/75 R16		TR-13	15
	13	DTE010	265/75 R16		TR-13	15
	14	DTE011	235/70 R16		TR-13	18
	15	DTE012	245/70 R16		TR-13	15
	16	DTE013	255/70 R16		TR-13	15
	17	DTE014	265/70 R16		TR-13	15
	18	DTE016	285/75 R16		TR-13	12
	19	DTE017	295/75 R16		TR-13	12
	20	DTE020	315/75 R16		TR-13	10

TUBES FOR LIGHT TRUCKS

		CODE	SIZE	ADDITIONAL DESCRIPTION	VALVE	Q-TY PER BOX
12"	1	DEC278	145/155-12	145/155R12	V3.02.5	30
	2	DEC279	165/70-13	165/70R13	V3.02.5	35
14"	3	DEC280	165/175/70-14	165/175/70R14	V3.02.7	30
	4	DEC282	5.90-14	5.90R14	V3.02.18	30
	5	DEC281	195/205-14	195/205R14	V3.02.7	20

		CODE	SIZE	ADDITIONAL DESCRIPTION	VALVE	Q-TY PER BOX
15"	6	DEC230	6.00-15	6.00R15	V3.02.7	25
	7	DEO059	JR 78-15		TR-15	20
	8	DEC187	215/225/235/70-15	MR 15 215/225/235/70R15	V3.02.18	18
16"	9	DEO011	6.00/6.50-16	6.00/6.50R16	TR-15	20
	10	DEO036	6.00/6.50-16	6.00/6.50R16	TR-13	20
	11	DEO030	6.00/6.50-16	6.00/6.50R16	V3.02.18	20
	12	DEO033	6.00/6.50-16	6.00/6.50R16	TR-75A	20
	13	DECO79	7.50/8.25-16	7.50/8.25R16	V3.02.8	12
	14	DEO034	YK-16-01 175/185-16	GR16 YKR16-01 175/185R16	TR-13	25
	15	DEO016	195/205/215/70-16	KR16 195/205/215/70R16	TR-13	20
	16	DEO065	195/205/215/70-16	KR16 195/205/215/70R16	TR-15	20
	17	DER167	7.00/7.50-16	7.00/7.50R16	TR-13	18
	18	DEO058	225/235/245/255/70-16	MR16 225/235/245/255/70R16	TR-13	18

AGRICULTURAL EQUIPMENT AND FORESTRY

		CODE	SIZE	ADDITIONAL DESCRIPTION	VALVE	Q-TY PER BOX
12"	1	DEO047	5.00-12		TR-218A	30
	2	DEO060	6.00-12		TR-15	40
	3	DER283	10.0/80-12		TR-13	15
	4	DET103	10.0/80-12		V3.02.7	15
	5	DER146	10.0/80-12		JS-2	15
	6	DER118	10.0/80-12		TR-15	15
14.5"	7	DER360	200/60-14.5		TR-13	25
	8	DER364	200/60-14.5		TR-15	25
	9	DER263	30x11.5/14.5		V3.02.8	12
15"	10	DER180	30x11.5/14.5		V3.02.2	12
	11	DER132	5.00-15		TR-15	35
	12	DER213	6.00-15		TR-218A	25
	13	DEO027	6.70/7.50-15		TR-15	20
	14	DEO041	7.5L-15		TR-15	20
	15	DER261	7.5L-15		TR-218A	20
	16	DER480	7.5/9.5LR14/15		TR-13	20
	17	DER140	12.5/60-15		TR-15	12
15.3"	18	DER010	4.00/60-15.5		TR-15	8
	19	DER005	10.0/75-15.3		TR-15	15
	20	DER006	10.0/75-15.3		TR-218A	15
	21	DER007	11.5/80-15.3		TR-15	12
	22	DER211	11.5/80-15.3		TR-218A	12
	23	DER497	11L15		TR-15	12
	24	DER539	12.5L 15/16		TR-15	12
	25	DER009	12.5/80-15.3		TR-15	10
15.5"	26	DER181	400/60-350/70-15.5		TR-15	10
	27	DER200	400/60-350/70-15.5		TR-218A	10
	28	DEC427	400/60-350/70-15.5		TR-150	10
	29	DER182	500/55/60-15.5		TR-15	10
16"	30	DER046	4.00/4.50-16		TR-15	40
	31	DER001	6.00-16		TR-15	25
	32	DER325	6.00-16		TR-218A	25
	33	DER326	6.50-16		TR-218A	20
	34	DER496	7.00-16		TR-15	18
	35	DER002	7.50-16		TR-15	18
	36	DEC474	7.50-16		TR-150	18
	37	DER199	7.50-16		TR-218A	18
	38	DER256	8.25-16		TR-218A	12
	39	DER003	9.00/10.00-16		TR-15	12
	40	DER272	9.00/10.00-16		TR-218A	12
	41	DER251	10.5-16		TR-218A	15
	42	DER045	10.5/65-16		TR-15	15
	43	DER144	11.00-16		TR-15	10
	44	DER145	11.00-16		TR-218A	10
	45	DER124	12.0/65/75-16		TR-15	10
	46	DER008	14.0/65-16		TR-15	10
	16.5"	47	DER253	10-16.5		TR-15
48		DER248	12-16.5		TR-15	12

		CODE	SIZE	ADDITIONAL DESCRIPTION	VALVE	Q-TY*
17"	49	DER087	15.0/55-17		TR-15	7
	50	DER292	15.0/55-17		TR-218A	7
	51	DER089	19.0/45-17		TR-15	5
	52	DER202	19.0/45-17		TR-218A	5
17.5"	53	DER270	215/75-17.5		TR-15	15
	54	DER481	14-17.5		TR-15	8
	55	DER482	14-17.5		TR-218A	8
18"	56	DER335	4.50/4.75/5.00-18		TR-13	40
	57	DER038	6.00-18		TR-15	15
	58	DER226	6.00-18		TR-87	15
	59	DER229	7.50-18		TR-15	15
	60	DER225	7.50-18		TR-218A	15
	61	DER275	7.50-18		V3.04.10	15
	62	DER128	10.5/80-18		TR-15	9
	63	DER136	10.5/80-18		TR-218A	9
	64	DER020	12.5/80-18		TR-15	9
	65	DER021	12.5/80-18		TR-218A	9
	66	DER103	13.0/65-18		TR-15	9
	67	DER081	13.0/75-18		TR-218A	9
	68	DER350	14.5/80-18		TR-218A	8
	69	DER149	15.0/70-18		TR-15	8
70	DEC156	15.0/70-18		V3.04.23	6	
71	DEC178	16.5/70-18		TR-15	6	
19"	72	DER311	4.00/4.50/4.75/5.00-19		TR-13	20
	73	DER327	4.00/4.50/4.75/5.00-19		TR-15	20
	74	DER304	6.00-19		TR-15	15
	75	DER478	8.00-19		TR-13	15
	76	DER212	18-19.5		TR-15	6
19.5"	77	DER280	18-19.5		TR-218A	6
	78	DER298	18-19.5		TR-300	6
	79	DER141	6.50-20		SP-5	15
20"	80	DER019	7.00/7.50-20		SP-5	15
	81	DER054	6.50-20		TR-13	15
	82	DER044	6.50-20		TR-15	15
	83	DER004	7.00/7.50-20		TR-15	15
	84	DER308	8.00/9.5-20		TR-15	12
	85	DER086	8.00/9.5-20		TR-218A	12
	86	DEC479	10.00-20		TR15	10
	87	DER092	11.2-20	11.2/10-20 11.2R20 (280/85R20)	TR-218A	7
	88	DER121	10.5/80-20		TR-15	12
	89	DER110	10.5/80-20		TR-218A	12
	90	DER344	10.5/80-20		V3.06.8	12
	91	DER036	12.5/80-20		TR-15	7
	92	DER053	12.5/80-20		TR-218A	7
	93	DER247	14.5/80-20		TR-15	7
	94	DER090	14.5/80-20		TR-218A	7
	95	DER172	14.5/80-20		V3.02.18	6
	96	DER133	14.5/80-20		TRJ650	6
97	DER066	16.0/70-20	405/70-20	V 3.06.8	6	
98	DER230	16.0/70-20	405/70-20	V 3.04.5	6	
99	DER071	16.0/70-20	405/70-20	TR-218A	6	
100	DER070	16.0/70-20	405/70-20	TR-15	6	
101	DER361	20.0/70-20		TR-15	5	
102	DER405	260/70-280/70-20		TR-218A	12	
22"	103	DER363	8.3/9.5-22	260/70-22	TR-15	10
22.5"	104	DER372	8.3/9.5-22.5		TR-15	10
	105	DER316	10.00-R22.5		TR-300	10
	106	DER317	11.00-R22.5		TR-300	8
	107	DER318	12.00-R22.5		TR-300	8
	108	DER286	13-22.5		TR-300	6
	109	DER314	15-22.5	385/65-22.5	TR-300	5
	110	DER331	16.5/18-22.5		TR-300	5
	111	DEC215	16.5/18-22.5		TR-218A	5
	112	DER341	18-22.5	445/65-22.5	TR-15	5
	24"	113	DER050	8.3/9.5-24	8.3/8-24 9.5/9-24 8.3R24 9.5R24 (260/70R24 300/70R24 250/85R24)	TR-218A
114		DER011	11.2/12.4-24	11.2/10-24 12.4/11-24 11.2R24 12.4R24 (320-360/70R24 280-320/85R24)	TR-218A	7



		CODE	SIZE	ADDITIONAL DESCRIPTION	VALVE	Q*	
24"	115	DER373	13.00-24		TR-218A	7	
	116	DER375	13.00-24		TR - 220	7	
	117	DER022	14.00-24		TR-218A	6	
	118	DER300	14.00-24		TR - 220	6	
	119	DER374	13.6-24 (narrow)	13.6/12-24 13.6R24 (340/85R24)	TR-218A	7	
	120	DER012	13.6/14.9-24	13.6/12-24 14.9/13-24 13.6R24 14.9R24 (360-380-420/70R24 340-380/85R24)	TR-218A	6	
	121	DER027	14.9-24	14.9/13-24 14.9R24 (420/70R24 380/85R24)	TR-218A	6	
	122	DER277	15.5/80-24; 16.5/85-24	400/80-24	TR-218A	6	
	123	DER336	16.0/70-24		TR-218A	6	
	124	DER104	16.9-24	16.9/14-24 16.9R24 (420/85R24)	TR-218A	4	
	125	DER197	17.5-24	17.5LR24 (445/70R24 460/70R24)	TR-218A	4	
	126	DER527	18.4-24		TR-218A	4	
	127	DER414	19.5L24	19.5LR24 (500/70R24)	TR-218A	4	
	128	DER198	420-460/70-24		TR-218A	4	
	129	DER495	21.3-24	21.3R24	TR-218A	2	
	26"	130	DER313	13.6/14.9-26	13.6/12-26 14.9/13-26 14.9R26 (380-420/70R26 380/85R26)	TR-218A	5
		131	DER100	16.9/18.4-26	16.9/14-26 18.4/15-26 16.9R26 18.4R26 (480-540/70R26 480/80R26 460/85R26)	TR-218A	3
132		DER060	23.1-26	23.1/18-26 23.1R26 (620/75R26)	TR-218A	2	
133		DER388	28.1-26	28.1LR26	TR-218A	1	
26.5"	134	DER246	600/55-26.5		TR-218A	2	
	135	DER163	700/50-26.5		TR-218A	2	
28"	136	DER420	8.3/9.5-28	8.3/8-28 9.5/9-28 9.5R28	TR-218A	8	
	137	DER330	9.5/10-28		TR-218A	6	
	138	DER013	11.2/12.4-28	11.2/10-28 12.4/11-28 11.2R28 12.4R28 (320-360/70R28 280-320/85R28)	TR-218A	6	
	139	DER026	13.6-28	13.6/12-28 13.6R28 (380/70R28 340/85R28)	TR-218A	5	
	140	DER014	13.6/14.9-28	13.6/12-28 14.9/13-28 13.6R28 14.9R28 (380-420/70R28 340-380/85R28)	TR-218A	5	
	141	DER048	16.9-28	16.9/14-28 16.9R28 (480/70R28 420/85R28)	TR-218A	4	
	142	DER390	18.4-28	18.4/15-28 18.4R28	TR-218A	3	
	143	DER217	4.00-30		TR-15	20	
30"	144	DER303	14.9/15.5-30	(380/85R30)	TR-218A	4	
	145	DER030	16.9-30	16.9/14-30 16.9R30 (480/70R30 420/85R30)	TR-218A	4	
	146	DER031	18.4-30	18.4/15-30 18.4R30 (520/70R30 460/85R30)	TR-218A	3	
	147	DER309	21LR30, 23.1R30	23.1-30	TR-218A	2	
30.5"	148	DER323	600/55/60-30.5		TR-218A	2	
32"	149	DER095	8.3/9.5-32	8.3/8-32 9.5/9-32 8.3R32 9.5R32 (300/70-32 230/95-32)	TR-218A	8	
	150	DER015	11.2/12.4-32	11.2/10-32 12.4/11-32 11.2R32 12.4R32 (360/70R32 320/85R32)	TR-218A	5	
	151	DER306	24.5-32	24.5R32 (650/75R32)	TR-218A	2	
	152	DER391	30.5-32	30.5LR32	TR-218A	1	
34"	153	DER017	16.9/18.4-34	16.9/14-34 18.4/15-34 16.9R34 18.4R34 (540/65R34 480-520/70R34 420-460/85R34)	TR-218A	3	
	154	DER387	20.8-34	20.8R34	TR-218A	3	
36"	155	DER084	4.00-36		TR-15	15	
	156	DER218	4.00-36		TR-218A	15	
	157	DER094	8.3/9.5-36	8.3/8-36 9.5/9-36 8.3R36 9.5R36 (210-230/95R36)	TR-218A	7	
38"	158	DER278	11.2/12.4-36	11.2/10-36 12.4/12-36 11.2R36 12.4R36 (320-360/70R36)	TR-218A	5	
	159	DER278	13.6-36	13.6/12-36 13.6R36 (380/70R36)	TR-218A	4	
	160	DER594	8.3/9.5-38	8.3/8-38 9.5/9-38 8.3R38 9.5R38	TR-218A	6	
	161	DER362	12.4-38	12.4/11-38 12.4R38 (360/70R38 320/85R38)	TR-218A	5	
	162	DER093	13.6/14.9-38	13.6/12-38 14.9/14-38 13.6R38 14.9R38 (380-420/70R38 380/80R38 340-380/85R38)	TR-218A	4	
	163	DER109	15.5-38	15.5R38 (420/70R38)	TR-218A	3	
	164	DER279	16.9-38	16.9/14-38 16.9R38 (480/70R38 420/85R38)	TR-218A	3	
	165	DER018	18.4-38	18.4/15-38 18.4R38 (520/70R38 460/85R38)	TR-218A	3	
	166	DER047	20.8-38	20.8R38 (520/85R38)	TR-218A	2	
	167	DER295	650/60-38	650/60R38	TR-218A	2	
40"	168	DER321	710/70-38 650/85-38	710/70R38 650/85R38	TR-218A	2	
	169	DER349	8.3/9.5-40	8.3/8-40 9.5/9-40 9.5R40	TR-218A	6	
42"	170	DER098	8.3/9.5-42	8.3/8-42 9.5/9-42 9.5R42 (230/95R42)	TR-218A	6	
	171	DER545	11.2/10-42	11.2R42 (300/85R42)	TR-218A	5	
	172	DER129	20.8-42	20.8R42 (580/70R42 520/85R42)	TR-218A	1	
	173	DER220	710/70-42	710/70R42	TR-218A	1	
44"	174	DER289	9.5/9-44	9.5R44 (230/95R44)	TR-218A	6	
	175	DER549	11.2-44	11.2R44	TR-218A	5	
46"	176	DER554	12.4-46	12.4R46 (320/90R46)	TR-218A	4	
	177	DER517	9.5/9-48	9.5R48 (230/95R48)	TR-218A	6	
48"	178	DER526	11.2/10-48	11.2R48 (270/95R48)	TR-218A	5	
	179	DER555	13.6/12-48	13.6R48 (340/90R48)	TR-218A	3	

* QUANTITY PER BOX

OFF THE ROAD

		CODE	SIZE	ADDITIONAL DESCRIPTION	VALVE	Q-TY PER BOX	
14"	1	DEO049	26x8.00-14	26x8.00R14	V3.04.10	20	
	2	DET047	27x8.50/10.50-15	27x8.50/10.50R15	TR-13	20	
15"	3	DET084	27x8.50/10.50-15	27x8.50/10.50R15	TR-15	20	
	4	DER315	29x12.00/12.50-15	29x12.00/12.50R15	TR-218A	15	
	5	DER169	31x10.50/11.50-15	31x10.50/11.50R15	TR-13	15	
	6	DER126	31x12.50/13.50-15	31x12.50/13.50R15	TR-13	12	
	7	DER138	31x15.50-15	31x15.50R15	TR-13	12	
	8	DER179	33x12.50/15.50-15	33x12.50/15.50R15	TR-13	12	
	24"	9	DEC058	14.00-24	14.00R24	TR-177A	6
		10	DER228	14.00-24	14.00R24	TRJ 1175C	6
11		DER091	20-24	20R24	TRJ-1175C	3	
12		DER403	20-24	20R24	TRJ-650	3	
13		DER305	21.3-24	21.3R24	V3.02.15	2	
14		DEC450	21.3-24	21.3R24	TR177A	2	
25"	15	DER119	15.5-25	15.5R25	TRJ 1175C	5	
	16	DER338	15.5-25	15.5R25	TRJ 4000	5	
	17	DER130	16.00-24/25	16.00R24/25	TRJ 1175C	4	
	18	DER107	17.00-25	17.00R25	TRJ 1175C	4	
	19	DER108	17.50-25	17.50R25	TRJ 1175C	4	
	20	DER345	17.50-25	17.50R25	TRJ 4000	4	
	21	DEC466	17.50-25	17.50R25	V3.02.17	3	
	22	DER102	18.00-25	18.00R25	TRJ 1175C	4	
	23	DER085	20.50-25	20.50R25	TRJ 1175C	3	
	24	DER337	20.50-25	20.50R25	TRJ 4000	3	
	25	DEC444	20.50-25	20.50R25	V3.02.17	3	
	26	DER061	23.5-25	23.5R25	TRJ 1175C	2	
	27	DER351	23.5-25	23.5R25	TRJ 4000	2	
	28	DER062	25.5-25	25.5R25	TRJ 1175C	2	
	29	DER074	26.5-25	26.5R25	TRJ 1175C	2	
	30	DEC468	26.5-25	26.5R25	V3.02.17	2	
	31	DER382	29.5-25	29.5R25	TRJ 1175C	1	
	33"	32	DER139	18.00-33	18.00R33	TRJ 1175C	3
33		DER358	21.00-33	21.00R33	V3.02.17	1	
34		DER385	21.00-33	21.00R33	TRJ 1175C	1	

TUBES FOR FORKLIFTS AND INDUSTRIAL CARS

		CODE	SIZE	VALVE	Q-TY PER BOX	
2"	1	DET062	200-50	TR-87	100	
	2	DET176	210X65/250-3	TR-87	100	
4"	3	DET157	2.50/2.80-4	TR-87	100	
	4	DET237	3.00-4	TR-87	100	
	5	DET035	3.00-4	TR-13	100	
	6	DET238	4.00-4	TR-87	100	
	7	DET034	4.00-4	TR-13	100	
	8	DET150	11x4.00-4	TR-13	100	
	9	DET229	11x7.00-4	TR-87	50	
	10	DET138	21x4	JS-2	35	
	5"	11	DET175	4.10/3.50-5	TR-13	100
		12	DET108	4.10/3.50-5	TR-87	100
13		DET271	11x4.00-5	TR-87	100	
14		DET148	11x6.00-5	TR-87	50	
15		DET102	23-5	TR-13	25	
16		DET011	23-5	GW 4B 50x65°	25	
17		DET100	23-5	V3.02.19	25	
6"	18	DET033	3.50/4.00-6	TR-13	75	
	19	DET022	3.50/4.00-6	TR-87	75	
	20	DET221	145/70-6	TR-87	75	
	21	DET088	13x5.00-6	TR-13	75	
	22	DET087	13x5.00-6	TR-87	75	
	23	DET036	15x6.00-6	TR-13	50	
	24	DET071	15x6.00-6	TR-87	50	
7"	25	DET198	3.50/4.00-7	TR-13	75	
	26	DET220	16x8-7	TR-87	35	

	CODE	SIZE	VALVE	Q-TY PER BOX	
8"	27	DET064	3.00/3.25-8	TR-13	75
	28	DET065	3.00/3.25-8	TR-87	75
	29	DET160	3.50-8	TR-87	75
	30	DET139	1.45/70-8	TR-87	75
	31	DET003	4.00-8	TR-87	75
	32	DET004	4.00-8	TR-13	75
	33	DET115	4.00-8	JS-2	75
	34	DET007	5.00-8	TR-87	50
	35	DET016	5.00-8	TR-13	50
	36	DET140	5.00-8	JS-2	50
	37	DET019	16X6.5/7.5-8	TR-13	35
	38	DET017	18x8.50/9.50-8	TR-13	30
	39	DET023	18x8.50/9.50-8	TR-87	30
	40	DET086	20x8.00/10.00-8	TR-13	30
	41	DET040	18x7-8	V3.02.5	35
	42	DET043	18x7-8	TR-13	35
43	DET118	18x7-8	JS-2	35	
9"	44	DET028	5.00-9	TR-15	50
	45	DET008	6.00-9	TR-87	40
	46	DET072	6.00-9	TR-13	40
	47	DET037	6.00-9	TR-15	40
	48	DET109	6.00-9	JS-2	40
10"	49	DET014	3.00/3.50/4.00-10	TR-13	50
	50	DET005	4.00/4.40-10	TR-13	50
	51	DET006	4.00-10	TR-87	50
	52	DET018	5.00-10	TR-13	50
	53	DET127	5.00-10	TR-15	50
	54	DET025	5.0/5.00-10	TR-218A	50
	55	DET009	6.50-10	TR-87	30
	56	DET143	6.50-10	TR-13	30
	57	DET078	6.50-10	JS-2	30
	58	DET144	18X8/8.50/10.50-10	TR-13	30
	59	DET066	20X8.00/10.00-10	TR-13	30
	60	DET112	21X7/8/9.00-10	GP-4	30
11"	61	DET135	23x9-10	JS-2	30
	62	DET203	23x9-10	TR75A	20
	63	DET050	23x9-10	V3.02.7	30
	64	DEO075	560X165-11	TR-87	40
	65	DET155	4.00-12	TR-15	60
	66	DET015	5.00-12	TR-13	35
	67	DET197	5.00-12	TR87	40
	68	DEO026	6.00-12	TR-218A	30
	69	DET068	6.5/80-12	TR-218A	30
	70	DET010	7.00-12	V3.02.18	20
12"	71	DET031	7.00-12	TR-75A	20
	72	DET117	7.00-12	JS-2	20
	73	DET039	7.00-12	TR-13	20
	74	DET069	7.00-12	TR-218A	20
	75	DET058	23x8.5/10.5-12	TR-13	20
	76	DET119	23x8.5/10.5-12	TR-15	20
	77	DET129	23x8.5/10.5-12	TR-218A	20
	78	DET059	23x10-12	TR-13	20
	79	DET110	26X12.00-12	TR-13	15
	80	DET111	26X12.00-12	TR-15	15
	81	DET137	26X12.00-12	TR-218A	15
	82	DET107	27x10-12	V3.02.3	15
	83	DET079	27x10-12	JS-2	15
15"	84	DEO022	215-15	V3.06.18	20
	85	DET013	250-15	V3.02.18	18
	86	DET136	250-15	JS-2	20
	87	DET116	250/300-15	TR-75A	20
	88	DET046	300-15	V3.02.8	15
	89	DEC100	300-15	V3.04.10	15
	90	DER297	28X9-15	V3.02.18	20
	91	DER183	32X12.1-15	TR-177A	12
	92	DET152	7.00-15	JS-2	20

	CODE	SIZE	VALVE	Q-TY PER BOX	
15"	93	DET029	7.50-15	V3.02.8	18
	94	DET012	8.15-15	V3.02.18	20
	95	DET141	7.50/8.15-15	JS-2	20



FLOTATION / FORESTRY

	CODE	SIZE	VALVE	Q-TY PER BOX	
22.5"	1	DER158	400/55-22.5	TR-218A	5
	2	DER255	445/65-22.5	TR-218A	5
	3	DER159	500/45-22.5	TR-218A	3
	4	DER550	500/60-22.5	TR-218A	3
	5	DER176	500/550/60-22.5	TR-218A	3
	6	DER175	600/50-22.5	TR-218A	2
	7	DER177	600/55-22.5	TR-218A	2
	8	DER178	650/60-22.5	TR-218A	2
	9	DER168	700/45-22.5	TR-218A	2



MOTORCYCLE TUBES

	CODE	SIZE	VALVE	Q-TY PER BOX	
10"	1	DEM026	3.00/3.50-10	V1.09.1	50
	2	DEM001	3.00/3.50-10	TR-87	50
12"	3	DEM030	3.00/3.50-12	TR-87	50
	4	DEM002	3.00-12	V1.09.1	50
16"	5	DEM003	2.50/2.75/3.00-16	V1.09.1	50
	6	DEM031	3.00-16 HD	V1.09.1	25
	7	DEM004	3.50-16	V1.09.1	40
	8	DEM050	3.25/3.50-16 HD	V1.09.1	15
17"	9	DEM049	4.00-17 HD	V1.09.1	15
	10	DEM041	4.50-17	V1.09.1	30
	11	DEM042	4.50-17 HD	V1.09.1	20
	12	DEM056	4.50-17 HD cross	V1.09.1	15
18"	13	DEM046	3.00-18	V1.09.1	40
	14	DEM045	3.00-18 HD	V1.09.1	20
	15	DEM006	3.50-18	V1.09.1	40
	16	DEM035	3.50-18 HD	V1.09.1	20
	17	DEM051	3.50-18 HD cross	V1.09.1	15
	18	DEM007	4.00-18	V1.09.1	40
	19	DEM040	4.00-18 HD	V1.09.1	20
	20	DEM024	4.00/4.50-18	TR-13	40
	21	DEM008	4.75-18	V1.09.1	40
19"	22	DEM009	2.50/2.75-19	V1.09.1	40
	23	DEM009	3.00-19	V1.09.1	40
	24	DEM032	3.00-19 HD	V1.09.1	20
	25	DEM037	3.25/3.50-19 HD	V1.09.1	20
21"	26	DEM010	3.50-19	V1.09.1	40
	27	DEM012	2.75-21	V1.09.1	40
	28	DEM034	2.75-21 HD	V1.09.1	20
	29	DEM011	3.00-21	V1.09.1	40
	30	DEM033	3.00-21 HD	V1.09.1	20
	31	DEM044	3.00/3.25-21 HD	V1.09.1	20
22"	32	DEM013	2.75-22	V1.09.1	40
	33	DEM038	2.75-22 HD	V1.09.1	20
23"	34	DEM014	2.75-23	V1.09.1	40
	35	DEM039	2.75-23 HD	V1.09.1	20



SCOOTER TUBES

	CODE	SIZE	VALVE	Q-TY PER BOX
1	DMO001	2 1/4 -16/20 x 2.25	V1.06.1	75
2	DMO002	2 1/4 -17/21 x 2.25	V1.06.1	75
3	DMO003	2 3/4 -17/21 x 2.75	V1.06.1	75
4	DMO004	2 1/4 -19/23 x 2.25	V1.06.1	50
5	DMO005	2 1/2 -9	TR-87	75

FLAPS

	CODE	SIZE	WIDTH (mm)	Q-TY PER BOX
1	OCH033	23-5	95±5 mm	30
2	OCH029	5.00-8 (A-8)	75±3 mm	80
3	OCH031	18x7-8	100±3 mm	70
4	OCH039	6.00-9 (B-9)	100±3 mm	40
5	OCH032	6.50-10 (C-10)	130±5 mm	40
6	OCH034	7.00-12 (C-12)	120±5 mm	35
7	OCH052	5.90/7.00-14	160±10 mm	10
8	OCH030	170-14,5	180±10 mm	10
9	OCH050	210-14,5	210±10 mm	10
10	OCH040	7.50/8.15-15 (C-15)	160±5 mm	20
11	OCH016	8.25-15 (E-15)	180±10 mm	10
12	OCH045	10.0/11.5-15.3 (D-15)	215±10 mm	10
13	OCH051	E-16 6.50/7.50/8.25-16 (E-16)	170±10 mm	10
14	OCH074	13.00-16	330±10 mm	10
15	OCH024	22-16	420±10 mm	2
16	OCH054	12.00/13.00-18 (F-18)	260±10 mm	10
17	OCH086	16.5-18 NEW 	345±10 mm	5
18	OCH008	6.50/7.50-20 (C-20)	135±10 mm	15
19	OCH009	8.25/9.00-20 (E-20)	180±10 mm	10
20	OCH053	10.00/11.00-20 F-20 narrow	200±10 mm	10
21	OCH010	10.00/11.00-20 (F-20) standard	220±10 mm	10
22	OCH020	12.00/13.00-20 (G-20)	250±10 mm	5
23	OCH025	14.00-20 (H-20)	300±10 mm	5
24	OCH028	16.00-20, 16/70-20 (I-20)	340±10 mm	4
25	OCH047	11.00/12.00-24	220±10 mm	6
26	OCH048	13.00/14.00-24	260±10 mm	5
27	OCH068	15.5/17.5/18-25	380±10 mm	3
28	OCH061	20.5-25	470±10 mm	2
29	OCH049	23.5-25 (F-25)	495±10 mm	2
30	OCH072	26.5-25	600±10 mm	1
31	OCH069	29.5-25	645±10 mm	1

O-RINGS

	CODE	SIZE	Q-TY PER BOX
1	AKC021	Rubber sealing ring - wedge Tyran 20 "	50
2	PGK437/OR6/24	Oring 24"x6,6	200
3	PGK263/OR6/25	Oring 25"x6,6	200
4	PGK247/OR10/25	Oring 25"x10	100
5	PGK248/OR10/29	Oring 29"x10	100
6	PGK249/OR10/33	Oring 33"x10	100
7	PGK250/OR10/35	Oring 35"x10	50
8	PGK251/OR10/39	Oring 39"x10	50
9	PGK252/OR10/45	Oring 45"x10	50
10	PGK253/OR10/49	Oring 49"x10	50
11	PGK346/OR13/51	Oring 51"x13	25
12	PGK347/OR13/57	Oring 57"x13	25

VALVES

TR-13

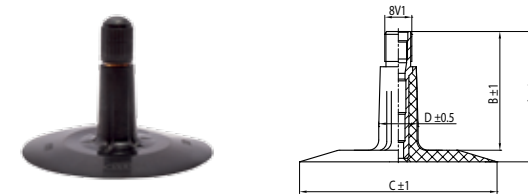

VALVE	A (mm)	B (mm)	C (dia mm)	D (dia mm)
TR-13	37	33.5	56	11.2

TR-15

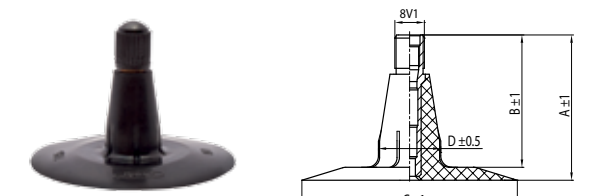

VALVE	A (mm)	B (mm)	C (dia mm)	D (dia mm)
TR-15	37	33.5	56	16.2

TR-150

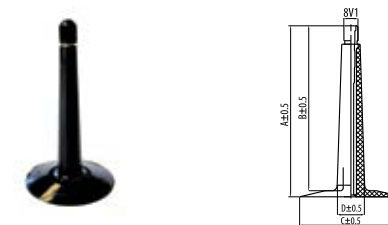

VALVE	A (mm)	B (mm)	C (dia mm)	D (dia mm)
TR-150	93	89.7	56	15

TR-218

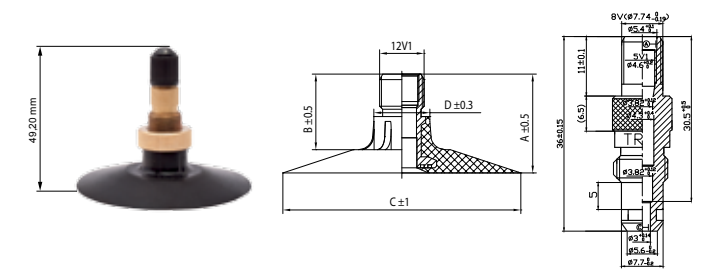

VALVE	A (mm)	B (mm)	C (dia mm)	D (dia mm)
TR-218A	27	20.65	64	15.9

TR-220

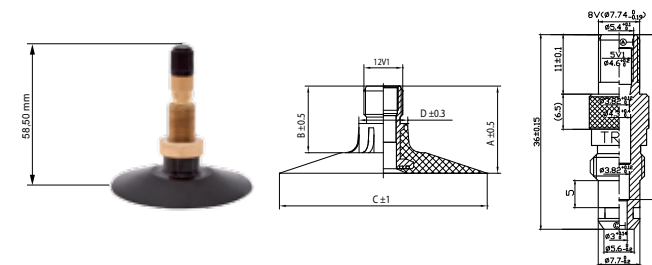

VALVE	A (mm)	B (mm)	C (dia mm)	D (dia mm)
TR-220A	36	29.65	64	15.9

TR-300

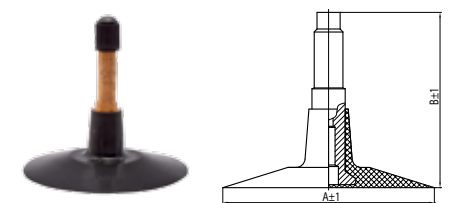

VALVE	A (mm)	B (mm)
TR-300	70	58

TRJ1175C

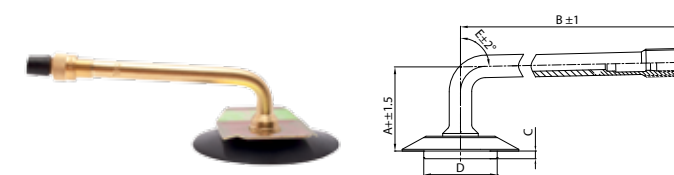

VALVE	A (mm)	B (mm)	C (dia mm)	D (dia mm)	E°
TRJ1175C	35	105	4	32	88

TRJ4000-6

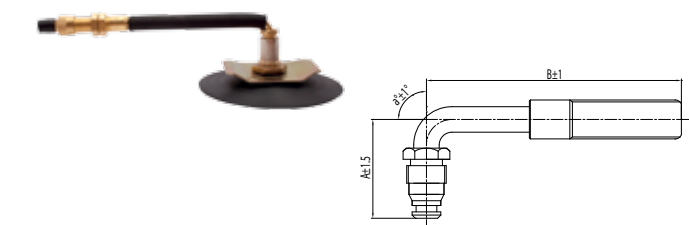

VALVE	A (mm)	B (mm)	a°
TRJ4000-6	31	139.7	90

VS3-21-1

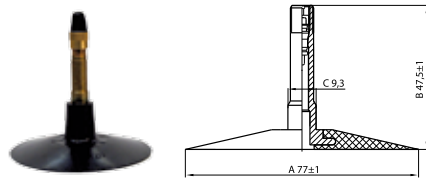

VALVE	A (mm)	B (mm)	C (dia mm)
VS3-21-1	77	47.5	9.3

TR75A*

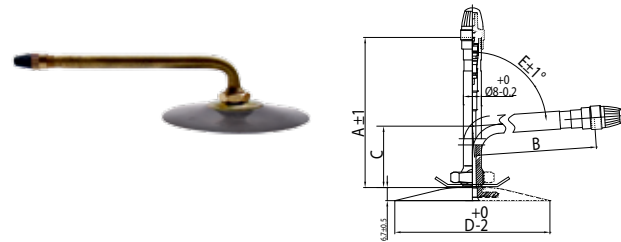

VALVE	A (mm)	B (mm)	C (mm)	D (dia mm)	E°
TR75A	95	76	24	82	86
TR77A	124	105	24	82	86
TR78A	146	127	24	82	86
TR177A	114	95	24	82	86
TR179A	160	141	24	82	86

PK-5A-145

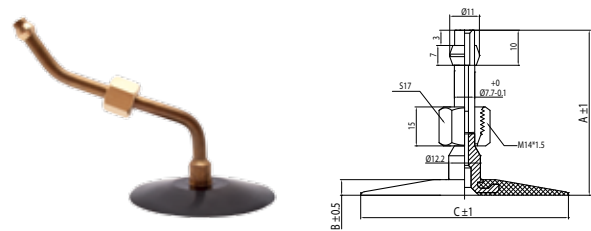

VALVE	A (mm)	B (mm)	C (dia mm)
PK-5A-145	145	6.7	76

V590

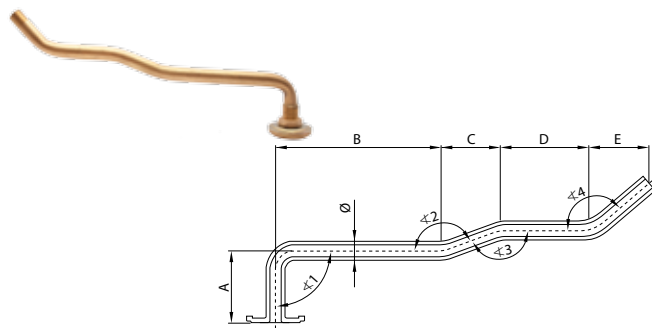

VALVE	A(mm)	B(mm)	C(mm)	D(mm)	E(mm)	Ø(mm)	α1	α2	α3	α4
V590	38.5	90	30	50	30	10.2	90°	160°	160°	140°

V3.02...



VALVE	A (mm)	B (mm)	α°
V3.02.1	25.5	41.5	120°
V3.02.2	22.5	43	120°
V3.02.3	33	44.5	95°
V3.02.4	39.5	44.5	110°
V3.02.5	20.5	47.5	90°
V3.02.6	23.5	60.5	110°
V3.02.7	22.5	71.5	100°
V3.02.8	20.5	89.5	94°
V3.02.9	20.5	99.5	94°
V3.02.10	20.5	115	94°
V3.02.11	20	126	98°
V3.02.12	20.5	132	94°
V3.02.13	20.5	133.5	90°
V3.02.14	20.5	138.5	94°
V3.02.15	20.5	145.5	94°
V3.02.16	20.5	149.5	90°
V3.02.17	20.5	156.5	90°
V3.02.18	22.5	74.5	90°
V3.02.19	20.5	60	94°
V3.02.20	22.5	56.5	95°
V3.02.21	20.5	172	90°
V3.02.23	29.5	66.5	90°
V3.02.24	20.5	117	90°
V3.02.26	20.5	105	94°
V3.02.27	20	75	94°
V3.02.29	20	127	94°

V3.04...

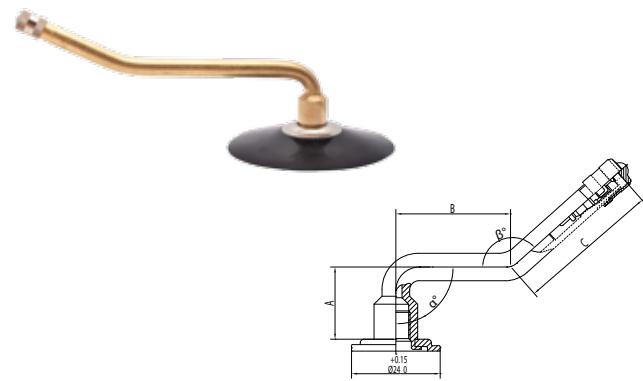

VALVE	A (mm)	B (mm)	C (mm)	α°	β°
V3.04.1	20.5	32	37	90°	138°
V3.04.2	20.5	38	41.5	90°	153°
V3.04.3	20	59	38.5	94°	163°
V3.04.4	20	74	40	94°	144°
V3.04.5	20	76	47.5	90°	153°

V3.04...

VALVE	A (mm)	B (mm)	C (mm)	α°	β°
V3.04.6	20	86	47.5	90°	153°
V3.04.7	20.5	30.5	38	90°	154°
V3.04.8	20.5	36.5	43	90°	167°
V3.04.10	20.5	47	53	90°	154°
V3.04.11	20.5	47	63.5	90°	154°
V3.04.12	20.5	60.5	60.5	90°	159°
V3.04.14	20.5	83.5	65	90°	159°
V3.04.15	20.5	42	38.5	90°	120°
V3.04.17	20	65	45	90°	160°
V3.04.18	20	72	45	90°	160°
V3.04.20	20	68	47	94°	164°
V3.04.21	20	83	57	94°	154°
V3.04.22	20	28	47	94°	164°
V3.04.23	20	48	47	94°	164°
V3.04.24	20	58	47	94°	164°
V3.04.25	20	80	47	94°	164°
V3.04.26	20	99	42	99°	189°

V3.06...

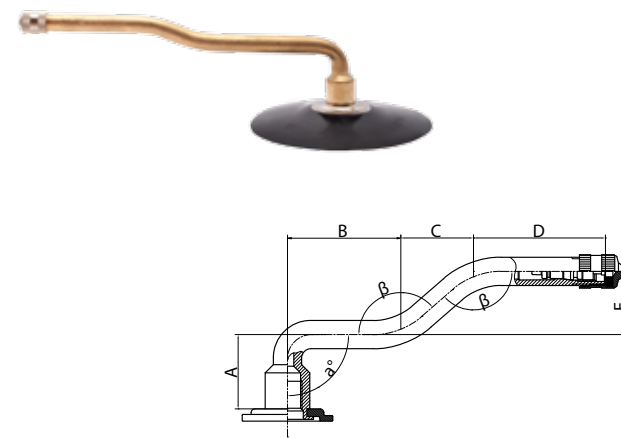

VALVE	A (mm)	B (mm)	C (mm)	D (mm)	E (mm)	α°	β°
V3.06.1	20.5	30.5	19.5	35.5	17	90°	139°
V3.06.2	20.5	44.5	12	37.5	17	90°	125°
V3.06.3	20.5	46	20.5	47.5	17	90°	139°
V3.06.4	32.5	46.5	20.5	46.5	17	95°	140°
V3.06.5	20.5	62.5	19.5	49	17	90°	139°
V3.06.6	20	79.5	19.5	37.5	17	90°	139°
V3.06.7	20.5	45.5	18.5	42.5	17	90°	137°
V3.06.8	24.5	61.5	14.5	50.5	7.5	94°	153°
V3.06.9	20.5	67.5	19.5	54.5	17	90°	139°
V3.06.12	23.5	71.5	19.5	25.5	11.5	90°	150°
V3.06.13	20	40	13	40	7	94°	153°
V3.06.14	20	50	13	40	7	94°	153°
V3.06.15	20	60	13	40	7	94°	153°
V3.06.16	20	62	13	50	7	94°	153°
V3.06.17	20	75	13	50	7	94°	153°
V3.06.18	20	82	30	35	10	94°	153°

V3.08...

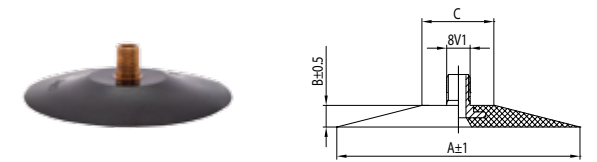

VALVE	A (mm)	B (mm)	C (dia mm)
V3.08.1	65	7	26
V3.08.2	70	7	26
V3.08.3	80	8	26
V3.08.4	57	5	26

SP-5 (TR-11) (V521)

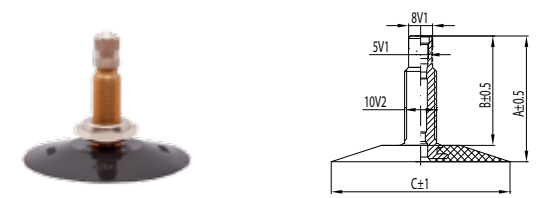

VALVE	A (mm)	B (mm)	C (dia mm)
SP-5	40	34.8	57

GP-4 (TR-4) (V1.09.1)

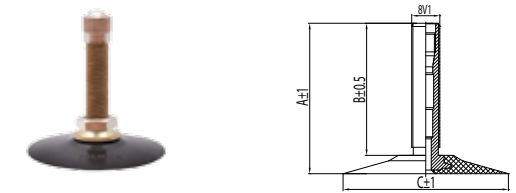

VALVE	A (mm)	B (mm)	C (dia mm)
GP-4	34.5	29.5	45

GP-3 (TR4A) (V1.06.1)



VALVE	A (mm)	B (mm)	C (dia mm)
GP-3	34	29.5	25

TR87

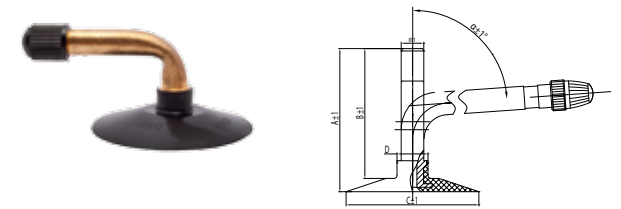

VALVE	A (mm)	B (mm)	C (dia mm)	D (dia mm)	α°
TR87	48	43.5	45	10.5	90

TR87A

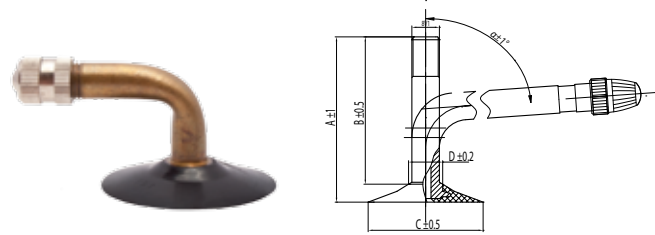

VALVE	A (mm)	B (mm)	C (dia mm)	D (dia mm)	a°
TR87A	46	41	32	9.5	90

JS2

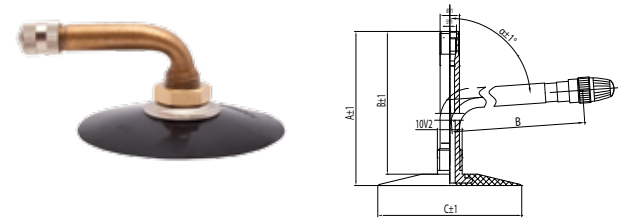

VALVE	A (mm)	B (mm)	C (dia mm)	a°
JS2	61	56.5	57	90

GW 4B 50°x60

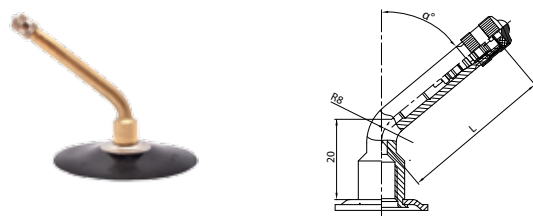

VALVE	L	a°
GW 4B 50°x60	60	50°

If required by the customer, inner tubes can be appointed to any valve offered by our company.

The valve pictures shown above are only examples and real valves can slightly differ from these. However all valves are manufactured according to technical specification shown above.

CAR RUGS

SLANT SET

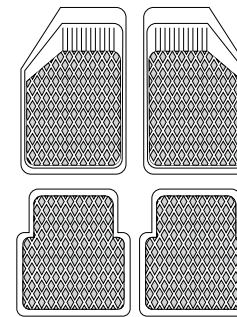

- | | | |
|--|---|--|
| AUDI A3
AUDI A4
BMW 1
BMW 3
BMW 5
CITROEN C2
CITROEN C3
CITROEN C4
CITROEN SAXO
DAEWOO MATIZ
DAEWOO TICO
FIAT CINQUECENTO
FIAT PANDA
FIAT PUNTO
FIAT SEICENTO
FORD FIESTA | FORD FOCUS
NISSAN ALMERA
OPEL CORSA
OPEL MERIVA
OPEL OMEGA
OPEL TIGRA
OPEL VECTRA
OPEL ZAFIRA
PEUGEOT 106
PEUGEOT 206
PEUGEOT 306
PEUGEOT 307
PEUGEOT 308
RENAULT CLIO
RENAULT LAGUNA
RENAULT MASTER | RENAULT MEGANE
ROVER 200
ROVER 45
SEAT ALHAMBRA
SEAT CORDOBA
SEAT IBIZA
SEAT LEON
SEAT TOLEDO
SCODEA FABIA
TOYOTA AVENSIS
TOYOTA COROLLA
VOLKSWAGEN BORA
VOLKSWAGEN GOLF
VOLKSWAGEN JETTA
VOLKSWAGEN PASSAT
VOLKSWAGEN POLO |
|--|---|--|

TONGUE SET

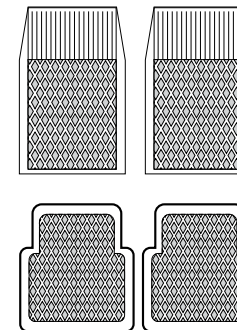

- AUDI A3
- AUDI A4
- CITROEN SAXO
- DAEWOO MATIZ
- DAEWOO TICO
- FIAT PUNTO
- FORD FIESTA
- OPEL CORSA
- OPEL VECTRA
- PEUGEOT 106
- PEUGEOT 206
- PEUGEOT 406
- SEAT TOLEDO
- VOLKSWAGEN GOLF
- VOLKSWAGEN PASSAT

MATIZ REAR

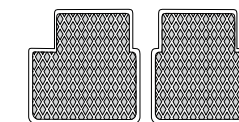

- CITROEN BERLINGO
- CITROEN SAXO
- DAEWOO ESPERO
- DAEWOO MATIZ
- DAEWOO NEXIA
- FIAT PUNTO
- FORD FIESTA
- FORD ESCORT
- HYUNDAI ACCENT
- MAZDA 121
- NISSAN MICRA
- OPEL ASTRA
- OPEL CORSA
- OPEL VECTRA
- OPEL ZAFIRA
- SUZUKI SWIFT
- TOYOTA YARIS

TONGUE FRONT

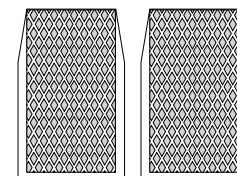

- | | |
|--|---|
| AUDI A6
CITROEN XANTIA
DAEWOO LANOS
DAEWOO NEXIA
DAEWOO NUBIRA
FIAT BRAVA
FIAT BRAVO
FORD MONDEO
HONDA CIVIC | HYUNDAI ACCENT
MAZDA 121
MAZDA 323
NISSAN MICRA
NISSAN PRIMERA
POLONEZ
SCODEA OCTAVIA
SUZUKI SWIFT |
|--|---|

TONGUE WIDE REAR

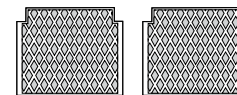

- AUDI 80
- AUDI 100
- AUDI A6
- LADA 2105
- LADA 2107
- VOLKSWAGEN PASSAT B3

TONGUE REAR

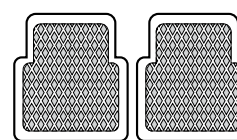

- | | |
|---|--|
| BMW 1
BMW 3
BMW 5
CITROEN C2
CITROEN C3
CITROEN C4
FIAT CINQUECENTO
FIAT PANDA
FIAT SEICENTO
FORD FOCUS
NISSAN ALMERA
OPEL MERIVA
OPEL OMEGA
OPEL TIGRA
OPEL ZAFIRA
PEUGEOT 306
PEUGEOT 307 | PEUGEOT 308
RENAULT CLIO
RENAULT LAGUNA
RENAULT MASTER
RENAULT MEGANE
ROVER 200
ROVER 45
SEAT ALHAMBRA
SEAT CORDOBA
SEAT IBIZA
SEAT LEON
SCODEA FABIA
TOYOTA AVENSIS
TOYOTA COROLLA
VOLKSWAGEN BORA
VOLKSWAGEN JETTA
VOLKSWAGEN POLO |
|---|--|

SLANT FRONT

- CITROEN BERLINGO
- OPEL ASTRA
- RENAULT KANGOO
- RENAULT SCENIC
- TOYOTA YARIS

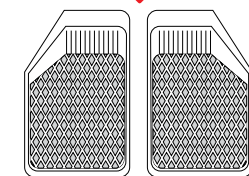

MATS

785 x 590 x 17 mm 1000 x 1500 x 22,5 mm or cut to the length	500 x 380 mm	585 x 390 x 17 mm	1200 x 1850 x 25 mm
--	--------------	-------------------	---------------------

PACKING

310 x 310 x 470 mm

20' container = 588

1 pallet = 35

26 pallets =

Tubes are packed in cardboard boxes 470x310x310mm
 35 boxes are bundled on 1 block pallet (1000x1200x1850mm)
 26 block pallets on truck trailer
 910 boxes are packed on a truck trailer
 588 boxes are packed in 20' container

WE ALSO OFFER...

...other Kabat brand products made in Poland:

- AGRICULTURAL TYRES
- SOLID TYRES
- RETREADED TYRES
- RUBBER COMPOUNDS
- MOULD PRODUCTS
- EXTRUSION PROFILES

More information available on our website:
www.kabat.pl





since 1983

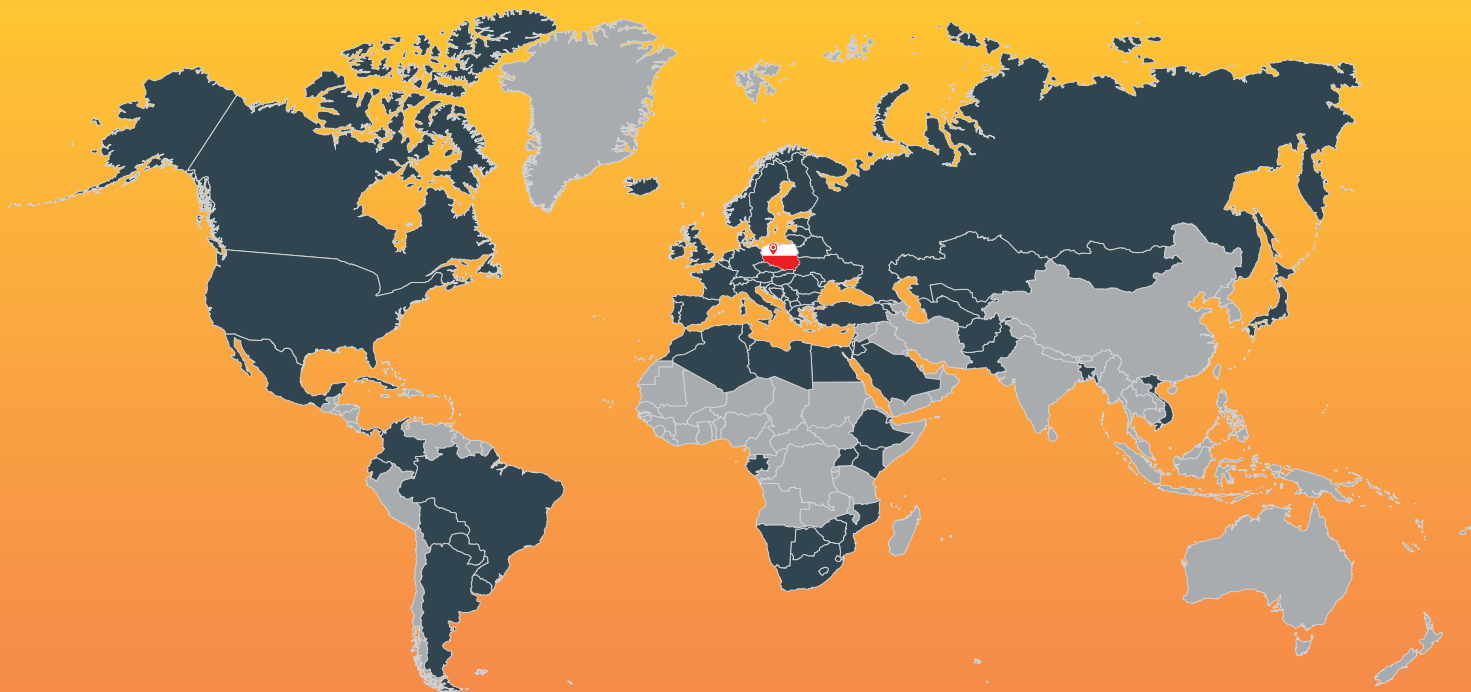

Kabat
– Europe's fastest and most
flexible inner tube supplier.
We supply in most other
countries worldwide.

Kabat Tyre Spółka z ograniczoną odpowiedzialnością Spółka jawna
64-840 Budzyń, ul. Gumowa 6, POLAND
phone +48 67 283 41 00, fax +48 67 283 41 58
e-mail: export@kabat.pl, export.kabat@gmail.com | www.kabat.pl